

INSTRUCTION MANUAL FOR

OSCILLOSCOPE

MODEL 553A

KIKUSUI ELECTRONICS CORPORATION

TABLE OF CONTENTS

|  | <u>PAGE</u> |
|--|-------------|
| 1. GENERAL .....                         | 1           |
| 2. SPECIFICATIONS .....                  | 2           |
| 3. OPERATION PROCEDURE .....             | 8           |
| 3.1 DESCRIPTION OF THE FRONT PANEL ..... | 8           |
| 3.2 DESCRIPTION OF THE REAR PANEL .....  | 13          |
| 3.3 PRECAUTIONS .....                    | 14          |
| 3.4 OPERATING PROCEDURE .....            | 15          |
| 4. MEASUREMENTS .....                    | 23          |
| 4.1 CONNECTION OF INPUT SIGNAL .....     | 23          |
| 4.2 VOLTAGE MEASUREMENT .....            | 25          |
| 4.3 TIME MEASUREMENT .....               | 27          |
| 5. CIRCUIT DESCRIPTION .....             | 33          |
| 5.1 VERTICAL CIRCUIT .....               | 33          |
| 5.2 HORIZONTAL CIRCUIT .....             | 35          |
| 5.3 SENSITIVITY CALIBRATOR .....         | 36          |
| 5.4 HIGH VOLTAGE RECTIFIER CIRCUIT ..... | 36          |
| 5.5 CRT CIRCUIT .....                    | 36          |
| 5.6 POWER SUPPLY .....                   | 37          |
| 6. CALIBRATION .....                     | 38          |

## 1. GENERAL

Kikusui Model 553A Oscilloscope is a completely-solid-state highly-reliable dual-channel oscilloscope. It employs a 133-mm CRT.

The vertical axes are electron-switching dual channels, with frequency response of DC - 7 MHz and maximum sensitivity of 10 mV/cm. Dual-FET's are used in the input circuits to ensure extremely high stability.

The horizontal axis covers a wide sweep range of 1 S/cm ~ 1  $\mu$ S/cm. When the magnifier (magnification factor of 5) is used, the maximum sweep speed of 0.2  $\mu$ S/cm can be obtained.

The horizontal axis is incorporated with an external terminal, which provides a frequency response of 3 Hz ~ 200KHz and maximum sensitivity of 0.2 Vp-p/cm.

The oscilloscope provides a stabilized 1-kHz square-wave calibration signal.

The oscilloscope can be used for various applications including research and developments of electronic devices, for adjustments in production lines, for inspection and maintenance services, etc.

### CONSTRUCTION

The oscilloscope is supplied being accompanied by accessories as follows:

|                          |       |   |
|--------------------------|-------|---|
| Oscilloscope (main unit) | ..... | 1 |
| Accessories:             |       |   |
| Probes                   | ..... | 2 |
| Terminal adaptors        | ..... | 2 |
| Instruction manual       | ..... | 1 |

## 2. SPECIFICATIONS

### VERTICAL AXIS

| Item                                | Specification   | Remarks  |
|-------------------------------------|---|--|
| Sensitivity                         | 10 mV/cm ~ 20 V/cm, 11 ranges   | 1-2-5 sequence   |
| Attenuator accuracy                 | Better than $\pm 3\%$   |  |
| Continuous variation of sensitivity | Can be continuously attenuated by 2.5 times or over of value indicated by VOLTS/CM switch.<br><br>At 20 V/CM range, the sensitivity can be made 50 V/CM (non-calibrated). |  |
| Frequency response                  | DC coupling: DC - 7 MHz<br>AC coupling: 3 Hz - 7 MHz  |  |
| Rise time                           | Approx. 0.05 $\mu$ S  |  |
| Input impedance                     | 1 M $\Omega$ $\pm 2\%$ , parallel capacitance<br>38 pF $\pm 2$ pF   |  |
| Input terminal                      | UHF-type receptacle   | M-type also is applicable.                                 |
| Maximum allowable input voltage     | 10 mV/CM range: 400 V <sub>p-p</sub><br>Other ranges: 600 V <sub>p-p</sub>  | Voltage as DC + AC <sub>p-p</sub> , AC at less than 1 kHz. |
| Input coupling                      | AC and DC   |  |
| Trace shift by DC offset            | Less than 2 mm at sensitivity<br>10 mV/CM   |  |
|                                     |   |  |

|                                      |   |  |
|--------------------------------------|---|--|
| Operation modes of vertical channels | CH 1: CH 1 alone<br>CH 2: CH 2 alone<br>ALT: Dual channel, alternate sweeps of CH 1 and CH 2.<br>CHOP: Dual channel, chopped sweeps of CH 1 and CH 2. |  |
| Chop frequency                       | 100 kHz   |  |
| Polarity                             | Polarity of CH 1 alone can be inverted.   |  |

#### HORIZONTAL AXIS

| Item                                | Specification  | Remarks        |
|-------------------------------------|--|----------------|
| Sweep time                          | 1 $\mu$ S/CM ~ 1 S/CM, 19 ranges   | 1-2-5 sequence |
| Continuous variation of sweep time  | Can be continuously varied by 2.5 times or over of value indicated by TIME/CM switch. The maximum sweep time is 2.5 S/CM (non-calibrated). |                |
| Sweep time error                    | Within $\pm 5\%$ of value indicated by TIME/CM switch, when VARIABLE knob is set in CAL'D position.  |                |
| Sweep magnification                 | 5 times  |                |
| Sweep magnification error           | Add $\pm 5\%$ to sweep time error  |                |
| Shift caused by sweep magnification | Within 10 mm at SCT screen center  |                |

TRIGGER CIRCUIT

| Item                                | Specification   | Remarks  |
|-------------------------------------|---|--|
| Trigger signal source               | NORM: Displayed signal<br>CH2 ONLY: Signal of CH 2 only<br>LINE: AC line signal<br>EXT: External signal |  |
| Coupling                            | AC  |  |
| Polarity                            | "+" and "-"   |  |
| Internal trigger sensitivity        | 50 Hz ~ 5 MHz: 10 mm<br>20 Hz ~ 7 MHz: 20 mm  | As indicated with amplitude displayed on CRT screen.                   |
| External trigger sensitivity        | 50 Hz ~ 4 MHz: 1 V <sub>p-p</sub><br>20 Hz ~ 7 MHz: 2 V <sub>p-p</sub>                                  |  |
| AUTO                                | Satisfies the above-mentioned trigger sensitivity for frequencies higher than 50 Hz.                    |  |
| Triggering system                   | Triggered sweep and auto sweep  |  |
| Input impedance of external trigger | Approx. 50 k $\Omega$ , parallel capacitance less than 25 pF  |  |
| Maximum allowable input voltage     | 100 V <sub>p-p</sub>  | Voltage ad DC + AC <sub>p-p</sub> ; AC at frequencies lower than 1 kHz |
| Input terminal                      | Binding posts, 19 mm distance   |  |

EXTERNAL SWEEP AMPLIFIER

| Item                                | Specification  | Remarks   |
|-------------------------------------|--|---|
| Sensitivity                         | 1 V <sub>p-p</sub> /cm or over                       | When set in the 5 X MAG state, the sensitivity is magnified by 5 times, or becomes 0.2 V <sub>p-p</sub> /cm. or over. |
| Continuous variation of sensitivity | Can be attenuated by 10 times or over.               |   |
| Frequency response                  | 3 Hz ~ 200 kHz                                       | Within -3 dB; with the continuously variable attenuator set in the maximum sensitivity position.                      |
| Input impedance                     | Approx. 100 kΩ, parallel capacitance less than 60 pF |   |
| Maximum allowable input voltage     | 100 V <sub>p-p</sub>                                 |   |
| Input terminals                     | Binding posts, 19 mm distance                        |   |

Z AXIS

| Item        | Specification  | Remarks |
|-------------|--|---------|
| Sensitivity | Intensity modulation discernible when 10 V <sub>p-p</sub> input is applied |         |
| Polarity    | Intensity falls as positive signal is applied.                             |         |

CALIBRATION VOLTAGE

| Item                    | Specification  | Remarks |
|-------------------------|--|---------|
| Waveform                | Square wave  |         |
| Polarity                | Positive, reference level is 0 V (zero volts).           |         |
| Output voltage          | Selectable between 0.05 V, 0.5 V, and 5 V <sub>p-p</sub> |         |
| Output voltage accuracy | Better than $\pm 3\%$                                    |         |
| Frequency               | Approx. 1 kHz  |         |

CRT CIRCUIT

| Item                  | Specification                                      | Remarks           |
|-----------------------|--|-------------------|
| Type of CRT           | 133 mm, round                                      |                   |
| Fluorescent screen    | B1   |                   |
| Acceleration voltage  | Approx. 1600 V                                     | Post acceleration |
| Effective screen size | 10 cm (horizontal)<br>8 cm (vertical)              |                   |
| Unblanking            | DC coupling  |                   |
| Illumination          | Illumination of graticule is continuously variable |                   |



~~POWER REQUIREMENTS~~

| Item              | Specification | Remarks |
|-------------------|---------------|---------|
| Voltage           | _____ V       | ±10%    |
| Frequency         | 50 - 60 Hz    |         |
| Power consumption | Approx. 35 VA |         |

DIMENSIONS AND WEIGHT

| Item       | Specification                  | Remarks            |
|------------|--------------------------------|--------------------|
| Dimensions | 295 (H) x 206 (W) x 460 (D) mm | Maximum dimensions |
|            | 276 (H) x 206 (W) x 402 (D) mm | Cabinet only       |
| Weight     | Approx. 11 kg                  |                    |

ACCESSORIES

| Item                             | Q'ty |
|----------------------------------|------|
| Type 957M low-capacitance probes | 2    |
| Type 941B terminal adaptors      | 2    |
| Instruction manual               | 1    |

### 3. OPERATING PROCEDURE

#### 3.1 DESCRIPTION OF THE FRONT PANEL (Refer to Fig. 3-1.)

POWER ON-OFF: Main switch of the oscilloscope.

ILLUM: Controls the illumination of the graticule.

CALIB: Output terminal of sensitivity calibration voltage.

FOCUS: Controls focussing of CRT.

INTEN: Controls intensity of CRT.

#### VERTICAL

VOLTS/CM: Selects vertical deflection sensitivity.  
Calibrated to 11 ranges covering 0.01 ~ 20 V/cm  
when VARIABLE knob is set in the CAL'D position.

VARIABLE: Continuously-variable sensitivity control, to  
cover each range of VOLTS/CM switch.

POSITION: Vertical positioning of the trace.

INPUT: Vertical input terminal.

AC-DC-GND: Selects the input coupling mode between AC and  
DC. Under the GND state, the amplifier input is  
disconnected from the input terminal and is  
shorted to the ground.

CH 1 INV: When this pushbutton is depressed (the yellow  
mark is indicated), the polarity of the CH 1  
signal is inverted.

DC BAL: Semi-fixed resistor for DC balance adjustment of  
the vertical amplifier.

MODE: Selects operation modes of dual vertical channels as below.

CH 1: The oscilloscope operates as a single-channel instrument with CH 1 alone.

ALTER: CH 1 and CH 2 are alternately swept (the other trace is swept at the end of one trace). When sweep speed is below a certain limit (2 mS/CM or below), two traces cannot be simultaneously displayed. This mode is suitable for observation of phenomena of high repetition frequencies.

CHOP: CH 1 and CH 2 are chopped at a frequency of approximately 100 kHz to display the two traces on the screen. The traces actually are a number of very closely positioned dots. Therefore, waveforms cannot be successfully displayed at high sweep speed (10  $\mu$ S/CM and higher). This mode is suitable for observation of low frequency phenomena.

CH 2: The oscilloscope operates as a single-channel instrument with CH 2 alone.

#### TIME BASE

TIME/CM: Selects horizontal sweep time. The sweep time values are calibrated when the VARIABLE knob is set in the CAL'D position. When this switch is set in the EXT HORIZ position, the internal sweep generator circuit becomes idle and the horizontal amplifier input is connected to the HORIZ IN terminal. In this case the VARIABLE knob functions as a sensitivity control of the horizontal amplifier.

VARIABLE: For continuously-variable adjustment of horizontal sweep. This knob also functions as a sensitivity control of the horizontal amplifier.

EXT TRIG  
or  
HORIZ IN: This terminal is used in common for both as an external trigger input terminal and an external horizontal input terminal. The signal applied to the EXT TRIG IN terminal is used as the trigger signal. When the TIME/CM switch is set in the EXT HORIZ position, this terminal becomes the input terminal of the horizontal amplifier.

STABILITY: This semi-fixed resistor is for adjustment of the stability of the horizontal sweep generator.

POSITION: Horizontal positioning of the spot or trace.

PULL 5 X MAG: When the POSITION knob is pulled out to this side, the horizontal sweep is magnified by 5 times or the horizontal sensitivity is increased by a factor of 5. When the HORIZ IN terminal is used, the sensitivity becomes approximately 0.2 V<sub>p-p</sub>/cm if this knob is pulled out or approximately 1 V<sub>p-p</sub>/cm if this knob is pressed in.

#### TRIGGERING

SOURCE: Selects trigger signal source.

NORM: The signal being measured is used internally as the trigger signal. Both CH 1 and CH 2 signals are used as trigger signal.

CH 2 ONLY: CH 2 signal is used as trigger signal.

LINE: AC line frequency signal is used as trigger signal.

EXT: An external signal being applied to the EXT TRIG terminal is used as trigger signal.

SLOPE ±: Selects triggering slope between "+" (positive-going) and "-" (negative-going) of trigger signal waveform.

LEVEL: Determines the trigger start level on the trigger signal waveform. When this knob is turned to the extremely counterclockwise position (AUTO position), no trigger level selection is made but an automatic sweep mode of operation is made.

The Front Panel of 553A Oscilloscope

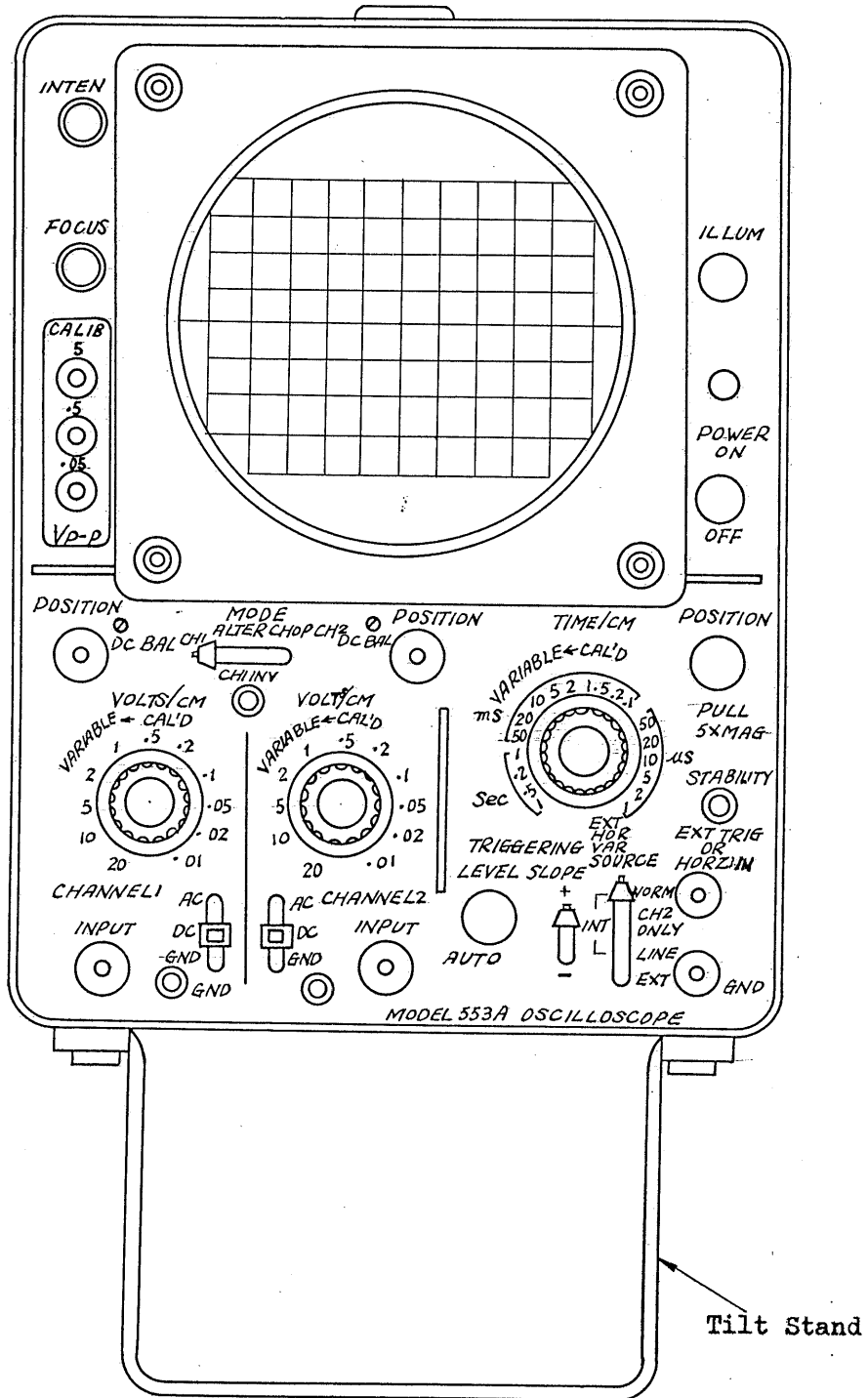

Fig. 3-1

### 3.2 DESCRIPTION OF THE REAR PANEL (Refer to Fig. 3-2.)

**CRT SELECTOR:** Selects the connection of CRT cathode. The upper position is for connection to the EXT CRT CATHODE terminal and the lower position is for connection to the chopped blanking signal. This switch normally is thrown to the lower position.

**EXT CRT CATHODE:** This terminal is used to apply an external signal (such as intensity modulation signal) to CRT. The intensity increases as a negative-going signal is applied.

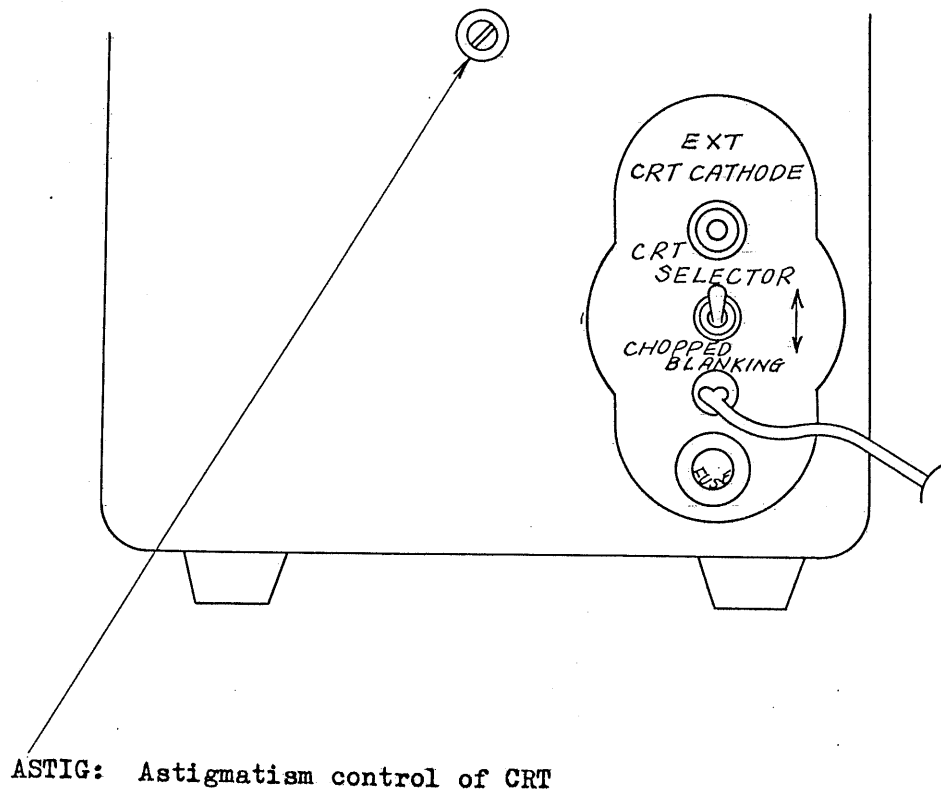

Fig. 3-2

### 3.3 PRECAUTIONS

#### (a) Line Voltage

This model is so designed to operate safely under the fluctuating range of the rated voltage within 10% in the primary supply. For the sake of obtaining high reliability and long durability of the components, it is recommended to use this model at the rated voltage as practicable as possible.

The high voltage supply power for cathode-ray tube is being stabilized, this model has a characteristic that there occurs a considerably less change in the deflection sensitivity caused either by controlling CRT's intensity or by the voltage fluctuation of the primary power supply and brightness control in monitoring can be easily done without affecting other functions.

#### (b) Environmental Conditions

The operating ambient temperature for the oscilloscope is  $0 \sim 40^{\circ}\text{C}$ . Avoid environments of dusty atmosphere and high humidity. When the oscilloscope is used being placed close to a heat generating device, pay attention to ensure sufficient ventilation. Do not use the oscilloscope in a strong magnetic field or corrosive gas atmosphere.

#### (c) Allowable Voltages of Input Terminals

The allowable maximum input voltages of the input terminals and probe are as shown below. Note that the input circuit may be damaged if a voltage higher than the specified maximum is applied.

Input terminals of CH 1 and CH 2:

400 Vp-p when VOLTS/CM switch is set in  
10 mV/CM position.

600 Vp-p when VOLTS/CM switch is set in other  
positions than 10 mV/CM.



Accessory probe: 600 Vp-p  
EXT HORIZ IN terminal: 100 Vp-p  
EXT TRIG IN terminal: 100 Vp-p  
Z-AXIS terminal: 100 Vp-p

(d) Beam Intensity

Do not make the beam intensity too high or leave the spot stationary for a long period of time in order to protect the CRT fluorescent screen against burning.

(e) Note on Deflection Characteristics

In order to minimize errors caused by amplitude distortion, measure the signals of higher than 4 ~ 5 MHz with deflection amplitudes of less than 4 cm on the CRT screen.

### 3.4 OPERATING PROCEDURE

Before turning on the power switch, set the controls of the front panel as below.

INTEN: Fully clockwise position  
FOCUS: Mid-position  
MODE: CH 1  
TRIGGERING LEVEL: AUTO  
SOURCE: NORM  
SLOPE: "+"

Connect the power cord to an AC power outlet, and turn on the power switch. A bright trace will appear on the screen in approximately 15 seconds. Turn counterclockwise the INTEN knob to obtain adequate trace brightness.

Focus Adjustment:

Move the trace to the screen center by adjusting the vertical and horizontal POSITION controls. So adjust the FOCUS control that the displayed image is made sharpest.

Signal Application and Displaying:

Display the internal calibration voltage of the oscilloscope itself on its CRT screen by connecting with lead wires the CALIB OUT terminal (0.05 Vp-p) to the INPUT terminal of CH 1. Set the controls as follows:

AC-DC-GND (CH 1): DC  
VOLTS/CM (CH 1): 10 mV  
VARIABLE (CH 1): CAL'D  
TIME/CM: 0.5 mS  
VARIABLE: CAL'D  
TRIGGERING LEVEL: AUTO

When the above is made, a square wave with a vertical amplitude of 5 cm will be displayed. As the VOLTS/CM switch is turned counterclockwise step by step, the vertical amplitude will decrease stepwise. As the VARIABLE control is turned counterclockwise, the amplitude will continuously decrease. These will show you the relationship of the VOLTS/CM switch and VARIABLE control with respect to the input signal level and the displayed waveform amplitude.

Time Axis and Triggering:

Since the repetition frequency of the calibration signal is approximately 1 kHz, one repetition cycle of the signal is displayed with a horizontal length of approximately 2 cm when the TIME/CM switch is set in the 0.5 mS position. As the TIME/CM switch is turned clockwise, the sweep time (sweep speed) increases. The sweep time is

continuously variable with the VARIABLE control. Thus, a certain section of the calibration signal can be displayed being expanded. As the TIME/CM switch is turned clockwise further, the rising edge of a pulse cycle will be displayed being expanded as shown in Fig. 3-3. If the SLOPE switch is changed from the "+" position to the "-" position, the sweep start point will be changed from the rising edge to the falling edge of the pulse wave.

As the TRIGGERING LEVEL knob is turned clockwise from the AUTO position, the trace disappears once. It re-appears as the knob is turned to a mid-position. By means of this knob the sweep start point is variable almost from peak to peak.

If the input of CH 1 is removed under the above sweeping state (the AC-DC-GND switch is changed to the GND state), the sweep will stop. For normal waveform observation, the LEVEL knob is set in the AUTO position.

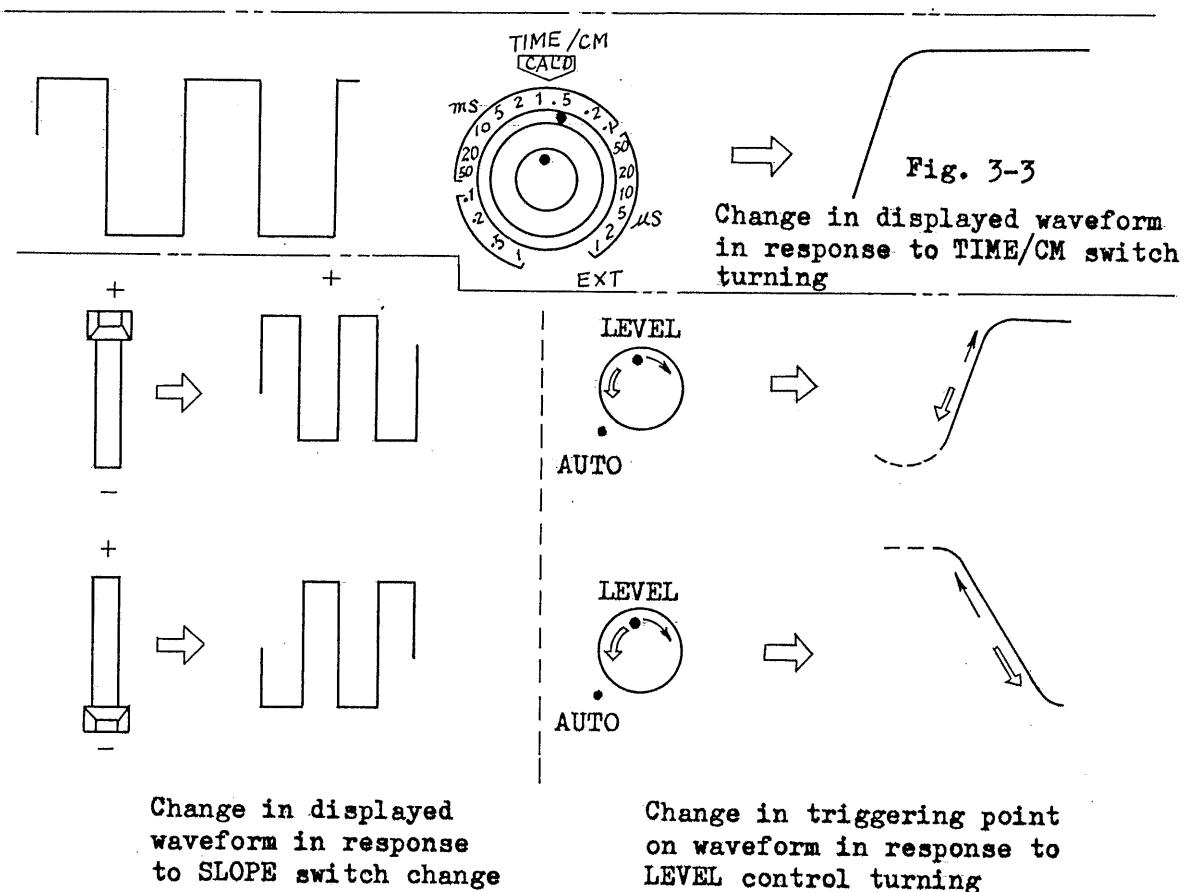

To display a stationary waveform on the screen, the input signal (the displayed signal) or an external signal which has certain periodical correlation with respect to the input signal must be applied to the trigger circuit of the time axis circuit. There are three triggering modes, namely, internal trigger, external trigger, and line trigger.

For internal triggering, the TRIGGERING SOURCE switch is set in the NORM position (for triggering with the input signal to be displayed on the screen) or in the CH 2 ONLY position (for triggering with the input signal of the CH 2 input terminal) so that either input signal is applied within the oscilloscope for trigger circuit.

For external triggering, the TRIGGERING SOURCE switch is set in the EXT position and the input signal itself or another signal which has a periodical correlation with the input signal is applied externally to the trigger circuit.

For line triggering, the TRIGGERING SOURCE switch is set in the LINE position. When this is done, an AC line frequency signal within the oscilloscope is applied to the trigger circuit.

Selection of trigger signal source with SOURCE switch

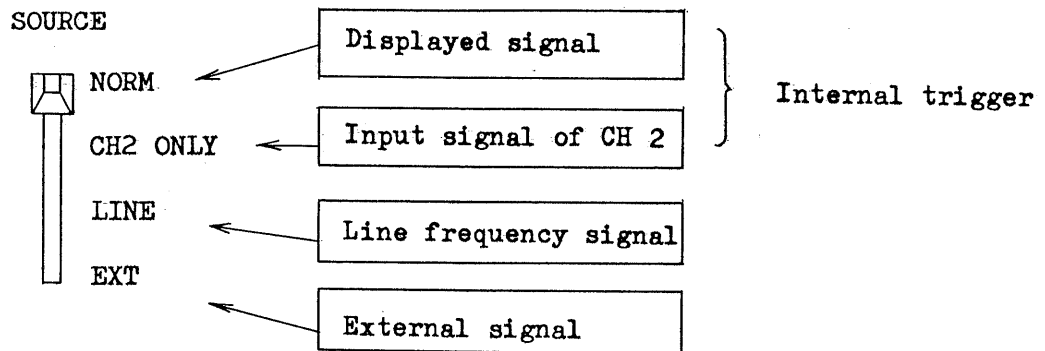

Fig. 3-5

### Internal Trigger (NORM and CH 2 ONLY)

For internal trigger mode of operation, the input signal is applied from a certain point of the vertical amplifier to the trigger circuit internally within the oscilloscope. When the SOURCE switch is set in the NORM position, the signal being displayed on the screen is used as the trigger signal; when the switch is set in the CH 2 ONLY position, the CH 2 input signal is used as the trigger signal. Since even a low level input signal is amplified to an appropriate level for triggering, the operating procedure is very simple.

### External Trigger (EXT)

With the internal trigger mode of operation, the triggering circuit is operated independent from the vertical amplifier circuit. With the internal trigger, the voltage applied to the trigger circuit may vary as the VOLTS/CM switch or the vertical POSITION control is turned and, therefore, the TRIGGER LEVEL control is required to be re-adjusted accordingly. With the external trigger, on the contrary, triggering is unaffected by setting of switches and controls of the vertical amplifier circuit and remains stable so far as the external trigger signal itself is not varied.

### Line Trigger (LINE)

An AC line frequency voltage produced in a secondary winding of the power transformer of the oscilloscope is directly applied to the trigger circuit. It is unaffected by the vertical amplifier circuit and can be effectively employed for observation of phenomena related to the AC line frequency.

### Sweep Magnification:

The input signal can be displayed in a horizontally enlarged waveform by using a fast sweep time. When a fast sweep time is used, however, the section required to be observed may move out of the

screen if the section is at a far point from the start of the sweep. In such a case, the PULL 5 X MAG switch may be pulled out so that the displayed waveform is expanded by a factor of 5. The actual sweep time in this case is one-fifth of the value indicated by the TIME/CM switch dial. The maximum sweep time of the oscilloscope when no sweep magnification is made is  $1 \mu\text{S}/\text{CM}$ ; when sweep magnification is made, it becomes  $0.2 \mu\text{S}/\text{CM}$ .

When sweep magnification is made, however, the trace intensity is reduced and there is a chance of forgetting to multiply by a factor of  $1/5$  the value indicated by the TIME/CM switch. Sweep magnification is not recommendable excluding the following cases:

- (1) A portion of the waveform positioned apart from the start point is required to be displayed.
- (2) A sweep speed faster than  $1 \mu\text{S}/\text{CM}$  is required.

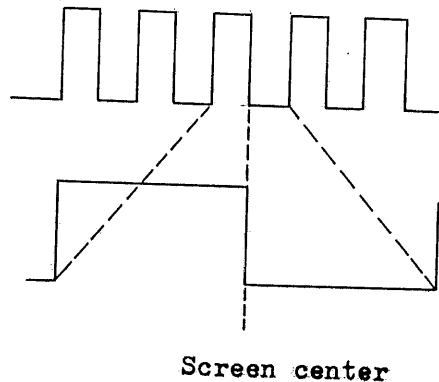

Fig. 3-6

#### Dual-Trace Operation:

Set the MODE switch in the ALTER position. With the operating procedure described in the above, the calibration signal waveform is displayed for CH 1 and a horizontal straight line is displayed for CH 2. Since triggering is made under the NORM mode or the displayed

signal is used as the trigger signal. Thus the trigger signal is not a continuous 1 kHz square-wave. It returns to zero at each cycle. This will make triggering unstable. So, apply the calibration signal to both CH 1 and CH 2 simultaneously. Now, two calibration signal waveforms will be displayed on the screen. Move the CH 1 waveform to the upper half of the screen and the CH 2 waveform to the lower half by turning the POSITION controls.

In this case also, the triggering is made in the NORM mode and the trigger signal is of the same waveform with that displayed on the screen as shown in Fig. 3-7, and, therefore, the triggering operation is unstable.

A stable triggering state can be obtained by turning the TRIGGERING SOURCE switch to the CH 2 ONLY position because, when this is done, triggering is not affected by the state of the signal to be displayed on the screen.

Displayed waveform

Triggering waveform when  
TRIGGER SOURCE switch is set  
in NORM position

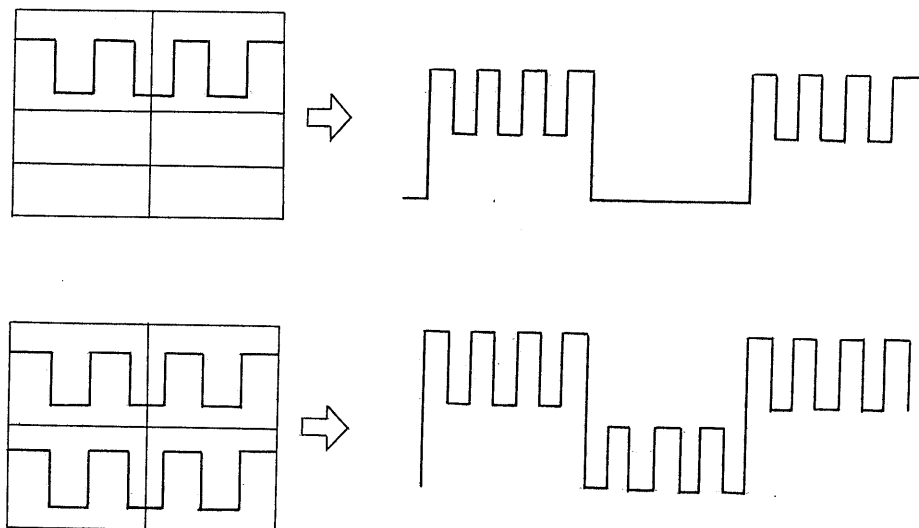

Fig. 3-7

Next, turn counterclockwise the TIME/CM switch to make faster the sweep speed. With the ALTER mode of operation in which CH 1 and CH 2 are alternately swept, the two waveforms cannot be simultaneously displayed on the screen.

To display two low frequency signals simultaneously on the screen in the dual trace mode, turn the mode switch to the CHOP position. In the CHOP mode, however, on the contrary to the ALTER mode, traces will be displayed as dotted lines at high sweep speeds.

By employing the ALTER mode or CHOP mode in accordance with the frequency of the measured signal as described in the above, signals for overall ranges of TIME/CM switch can be displayed in the dual-trace mode.

#### X-Y Scope Operation:

When the switches are set as below, the oscilloscope is ready to operate as an X-Y scope.

MODE: CH 1  
TIME/CM: EXT

Apply the calibration signal to CH 1 input terminal and EXT HORIZ IN terminal. Adjust the displayed waveform to an appropriate amplitude with the VOLTS/CM switch of CH 1 and HOR GAIN control. When this is done, two spots will be displayed at mutually diagonal positions. These spots represent a Lissajous' figure of frequency ratio 1:1 and phase difference zero degrees.



## 4. MEASUREMENTS

### 4.1 CONNECTION OF INPUT SIGNAL

The input impedance of the oscilloscope (as viewed from the signal input terminal) is 1 MΩ with 38 pF in parallel. When the accessory probe is used, the impedance is 10MΩ with 13 pF or less than in parallel. The signal may be applied to the input terminal of the oscilloscope in various methods, including the use of conventional covered wires, shielded cable, probe, or coaxial cable. A suitable method should be used taking the below-mentioned factors into consideration.

- (a) Output impedance of input signal source.
- (b) Voltage and frequency of input signal.
- (c) External induction noise.
- (d) Distance between input signal source and oscilloscope.

Connection methods may be classified by types of input signals as shown in Table 4-1.

Table 4-1

| Type of input signal |           | Connection method |     | Covered wire | Shielded cable | Probe | Coaxial cable | Others |
|----------------------|-----------|-------------------|-----|--------------|----------------|-------|---------------|--------|
|                      |           | Near              | Far |              |                |       |               |        |
| Low freq.            | Low imp.  | Near              |     | o            | o              | o     | o             |        |
|                      |           | Far               |     |              | o              |       | o             |        |
|                      | High imp. | Near              |     |              | o              | o     |               |        |
|                      |           | Far               |     |              |                | o     |               |        |
| High freq.           | Low imp.  | Near              |     |              |                | o     | o             |        |
|                      |           | Far               |     |              |                |       | o             |        |
|                      | High imp. | Near              |     |              |                | o     | o             |        |
|                      |           | Far               |     |              |                |       |               |        |

### Input with Covered Wires:

Connect the Type 941B Terminal Adaptor (supplied as an accessory) to the vertical input terminal of the oscilloscope, and connect the covered wires to the adaptor. This method is advantageous in that the procedure is simple and the signal is less attenuated. However, it is disadvantageous in that, when the wires are long and the output impedance of the signal source is high, external induction noise is introduced and signal observation is disturbed. Also, the stray capacity with respect to ground is large and the measured circuit is largely affected as compared with the case the accessory probe of 10:1 attenuation is used.

### Input with Shielded Cable:

External induction noise can be eliminated by using a shielded cable. However, the shielded cable has as large distribution capacity as 50 ~ 100 pF/meter and is not suitable when the output impedance of the signal source is large or when the signal frequency is high.

### Input with Probe:

The accessory probe of 10:1 attenuation has a shielded lead wire and provides a wide band attenuation with resistor  $R_p$  and parallel capacitor  $C_p$  as shown in Fig. 4-1. The use of the probe is advantageous when the output impedance of the input signal source is large or when the signal frequency is high.

Input impedance when the probe is used

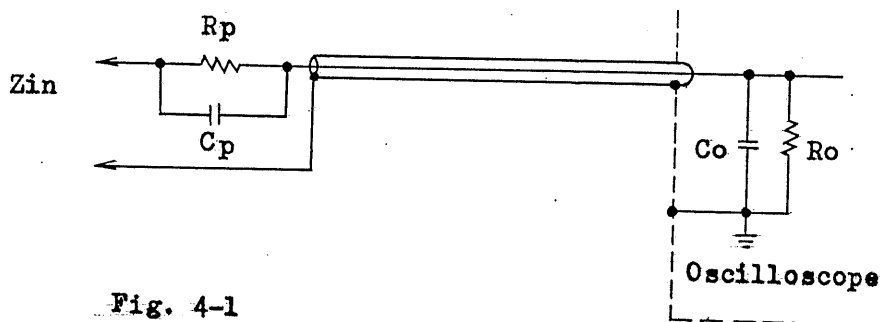

Fig. 4-1

$$Z_{in} = \frac{R}{\omega C R + 1}$$

$$R = R_p + R_o$$

$$C = \frac{C_p \times C_o}{C_p + C_o} \quad (C_p \text{ includes cable capacitance})$$

$$C_p = \frac{C_o \times R_o}{R_p}$$

#### Input with Coaxial Cable:

When the output impedance of the input signal source is 50 or 75 ohms, a coaxial cable of the matching impedance may be used so that signals up to high frequencies can be transmitted with less attenuation. For impedance matching, the input side of the oscilloscope should be terminated with a 50 or 75 ohm resistor as shown in Fig. 4-2.

Measured signal  
source

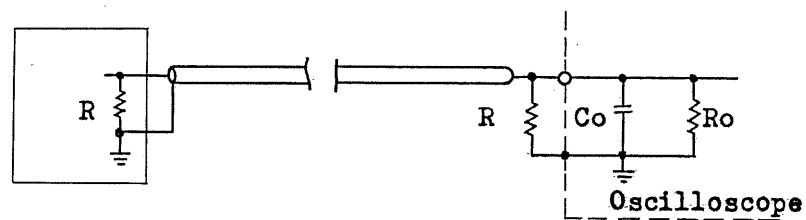

Fig. 4-2

## 4.2 VOLTAGE MEASUREMENT

### DC Voltage Measurement:

Set the time axis in the AUTO mode. Set the TIME/CM switch in the 1 mS/CM position or thereabout, and display a trace on the screen. Next, set the AC-DC-GND switch in the GND position. When this is done, the trace moves to the position corresponding to 0 V (zero

volts) of the vertical input signal as shown in Fig. 4-3. Move the trace to a position convenient for measurement. Then, move the AC-DC-GND switch to the DC position, apply the measured voltage of the measured point to the vertical input terminal, and read the resultant vertical displacement of the trace on the graticule.

If the trace is deflected out of the screen when the measured signal is applied to the input terminal, turn counterclockwise the VOLTS/CM switch to a position where the vertical displacement of the trace is convenient for measurement.

If the trace is deflected upward, the polarity of the measured signal is positive; if it is deflected downward, the polarity is negative. The voltage of the measured signal can be known from the reading (cm) on the graticule and equations (4-1) and (4-2) below.

When 10:1 probe is used:

$$\text{Voltage (V)} = (\text{Value indicated by VOLTS/CM}) \\ \times (\text{Deflection amplitude, cm}) \times 10 \dots\dots (4-1)$$

When signal is directly applied to input terminal:

$$\text{Voltage (V)} = (\text{Value indicated by VOLTS/CM}) \\ \times (\text{Deflection amplitude, cm}) \dots\dots\dots (4-2)$$

AC Voltage Measurement:

If the AC-DC-GND switch is set in the DC state for observation of a signal which has an AC component superimposed on a DC component as shown in Fig. 4-3, the AC component may run out of the screen and cannot be measured when the DC component is quite large as compared with the AC component. The AC component may possibly be brought back into the screen area by turning the vertical POSITION control. However, measurement under such state should be avoided because such will involve large errors. The AC component also may possibly be brought back into the screen area by turning the VOLTS/CM switch to a position for a reduced amplitude. This state also will make measurement inaccurate because the AC component is reduced to a very small amplitude as displayed on the screen.

For accurate measurement of an AC voltage superimposed on a DC voltage, the AC-DC-GND switch should be set in the AC state. When this is done, the DC voltage of the signal is blocked and the AC voltage alone is amplified and displayed with a sufficiently large amplitude for accurate measurement.

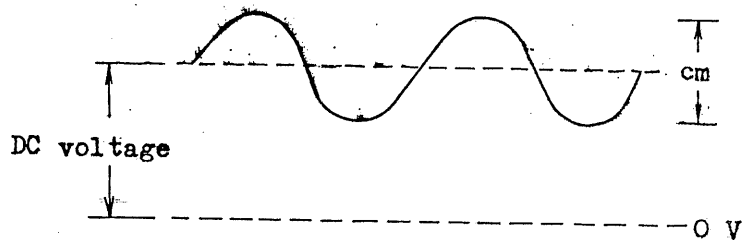

Fig. 4-3

The voltage of the measured signal can be known from the read amplitude (cm) and equations (4-1) and (4-2). (When the AC coupling is employed, the amplitude is attenuated by -3 dB at a low frequency of approximately 3 kHz.) The voltage obtained by calculating with equation (4-1) or (4-2) is peak-to-peak value. The voltage can be converted into the rms value by using equation (4-3).

$$\text{Voltage (V rms)} = \frac{\text{Voltage (V}_{p-p})}{2 \sqrt{2}} \dots\dots\dots (4-3)$$

#### 4.3 TIME MEASUREMENT

##### Time Interval Measurement:

The time interval (period) between two points on a waveform can be directly read on the graticule referring to the value indicated by the TIME/CM switch provided that the VARIABLE knob is set in the CAL'D position. For this measurement, set the TRIGGERING LEVEL switch in the AUTO state and turn the TIME/CM switch to a position where the two measured points are placed in an appropriate distance for measurement on the screen as shown in Fig. 4-4.

$$\text{Time } T \text{ (sec)} = \text{TIME/CM (sec)} \times \text{Distance on graticule (cm)} \\ \times \text{Reciprocal of magnification factor ..... (4-4)}$$

The reciprocal of the magnification factor is 1 when the sweep magnification operation is not employed or it is 0.2 when the sweep magnification operation is employed.

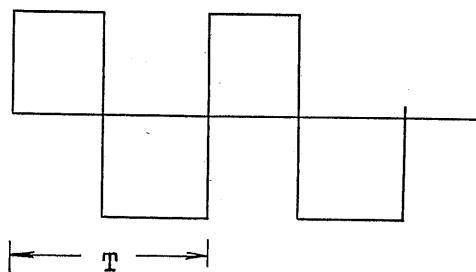

Fig. 4-4

Time Difference Measurement:

The time difference between two signals of the same frequency can be measured by operating the oscilloscope in the ALT or CHOP dual-trace mode. The measuring procedure is as follows: Set the TRIGGERING SOURCE switch in the CH 2 ONLY position. Apply the time-leading signal to CH 2 and the time-lagging signal to CH 1. Waveforms as shown in Fig. 4-5 will be displayed on the screen. Determine the distance T and calculate the time difference employing equation (4-4).

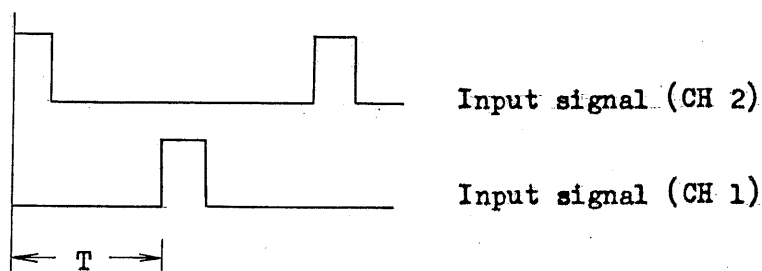

Fig. 4-5

Frequency Measurement:

For frequency measurement, the oscilloscope is applicable in three methods as below.

First, the period per one cycle is calculated using equation (4-4) and the frequency is calculated using equation (4-6).

$$\text{Frequency } f \text{ (Hz)} = \frac{1}{\text{Period } T \text{ (sec)}} \dots\dots\dots (4-6)$$

Second, the period for a few tens cycles (10 ~ 20 cycles) is determined, the number (N) of periods which falls within the 10-cm horizontal span of the graticule is determined, and the frequency is calculated using equation (4-7). This method is advantageous over the first method because it reduces measuring errors provided a sufficiently large number is employed as for N.

$$\text{Frequency } f \text{ (Hz)} = \frac{N}{\text{Indication of TIME/CM (sec) } \times 10} \dots\dots (4-7)$$

Third, the frequency can be measured by means of Lissajous' figure. While the frequency in the first and second methods is measured by determining the period, the frequency in the third method is determined by operating the oscilloscope as an X-Y scope when the measured signal is of a simple waveform (such as sine wave) and is of a frequency of below 10 kHz. To operate the oscilloscope as an X-Y scope, set the TIME/CM switch in the EXT HOR position. Apply the unknown signal to CH 1 input terminal and a reference signal to the EXT HORIZ IN terminal. Adjust both vertical and horizontal amplitudes to 4 cm by adjusting the VOLTS/CM switch and EXT HORIZ VAR control. Vary the frequency of the reference signal until a Lissajous' figure of 1:1 frequency ratio is displayed on the screen.

At the frequency ratio of 1:1, the Lissajous' figure is either circular, elliptical, or linear. As the frequency approaches 1:1, the Lissajous' figure continuously and repeatedly varies in the

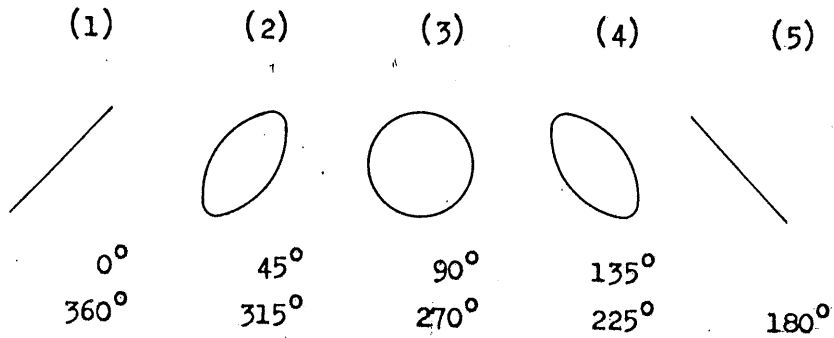

Fig. 4-8

sequence of from (1) to (5) and back to (1). As the frequency ratio becomes very close to 1:1, the repetitive variation becomes very slow and, ultimately, as the ratio becomes exactly 1:1, the figure becomes stationary. At this state the frequency of the measured signal is the same with that of the reference signal. The frequency of the measured signal not in the 1:1 ratio but in other integer or fraction ratios with respect to the reference signal also can be determined since ratios are represented by specific patterns of Lissajous' figure. However, measurement in the 1:1 ratio using a reference signal generator which covers a wide frequency range is most recommendable since this method is simple and accurate.

Phase Measurement:

Measurement in Lissajous' figure method (two signals of the same frequency):

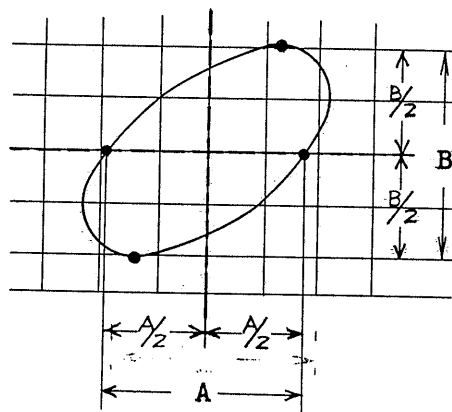

Fig. 4-9



To measure the phase difference between two signals of the same frequency, operate the oscilloscope as an X-Y scope and display a Lissajous' figure in the same manner as is made for frequency measurement. The phase difference can be calculated employing equation (4-8) and referring to Fig. 4-8 for the values of A and B.

$$\text{Angular phase} \quad \sin \theta = \frac{A}{B} \dots\dots\dots (4-8)$$

Measurement in dual-trace method (two signals of the same frequency):

Another method of measuring the phase difference between two signals of the same frequency is to operate the oscilloscope in the same manner as time difference measurement and set the TRIGGERING SOURCE selector in the CH 2 ONLY position. An example of measurement of phase difference between two sine waves is shown in Fig. 4-10.

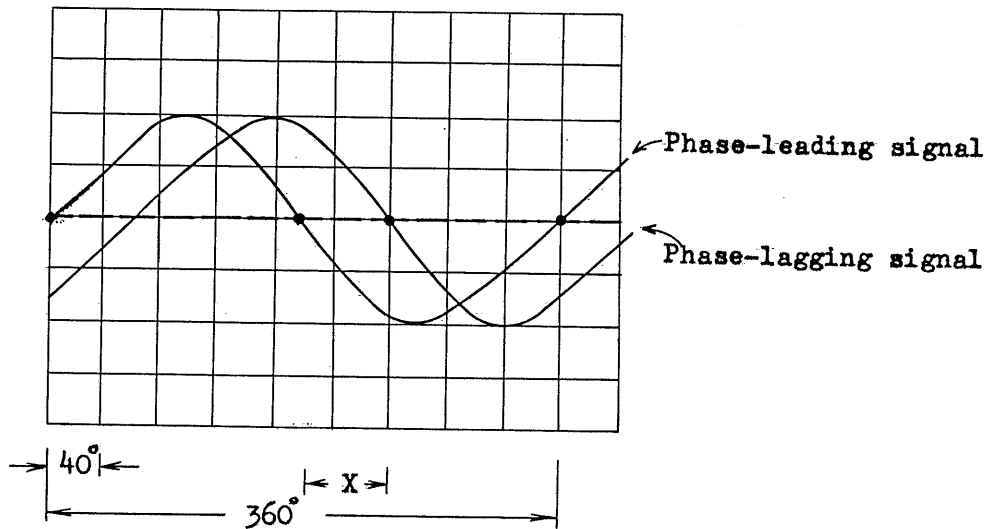

Fig. 4-10

The measuring procedure is as follows: Adjust one cycle of the signal to 9 cm of the horizontal graticule scale by turning the TIME/CM switch and VARIABLE knob. So adjust the TRIGGERING LEVEL control that the triggering level is accurately adjusted to the center line of the horizontal scale. An accurately adjusted state is shown in Fig. 4-10. Since one cycle is  $360^\circ$ , a horizontal span

of 1 cm corresponds to  $40^\circ$  of phase. Since the span of X in Fig. 4-10 is 1.5 cm, the phase difference is calculated as below.

$$\begin{aligned} \text{Phase difference (degrees)} &= \text{Distance between the leading} \\ &\quad \text{and lagging signals (X) } \times 40^\circ \dots \\ &\quad \dots\dots\dots (4-9) \end{aligned}$$

Measurement in dual-trace method (two signals of different frequencies):

When the frequencies of two signals are different (but are in an integer ratio relationship), triggering must be made with the signal of the lower frequency. Apply the lower frequency signal to CH 2 and the triggering must be made in the CH 2 ONLY mode. If the signals are applied in the reverse, triggering for the lower frequency signal cannot be successfully made.

## 5. CIRCUIT DESCRIPTION

### 5.1 VERTICAL CIRCUIT

The maximum sensitivity of the vertical amplifiers of the oscilloscope in the AC or DC coupling is 10 mV/CM. The amplifiers are a multi-stage differential type, and their initial stage employs FET transistors. Provisions are provided to improve temperature characteristics for the input three stages including the FET circuit.

- Input attenuator: The input attenuator (VOLTS/CM switch) provides 11 calibrated ranges. It is incorporated with frequency compensation feature.
- DC BAL: R209 or R223 are so adjusted that the source currents of Q201 and Q202 for CH 1 or those of Q205 and Q206 for CH 2 are made equal. When the circuits are correctly DC-balanced, the trace displayed on the CRT screen is not shifted when the VOLTS/CM switch or VARIABLE knob is turned.
- Input source follower: The functions of the input follower (Q201 and Q202 for CH 1 and Q205 and Q206 for CH 2) are to increase the input resistance and to isolate the effect of capacitance variation caused to the input circuit when the VARIABLE knob is turned. R202 and R203 (for CH 1) and R217 and R218 (for CH 2) are current limiting resistors which protect the FET transistors when abnormally high voltage is applied to the input.
- Emitter follower: The function of the emitter follower (Q203 and Q204 for CH 1 and Q207 and Q208 for CH 2) is to provide a low impedance driving output for the subsequent stage.

Differential amplifier: Q301 and Q302 (for CH 1) and Q314 and Q315 (for CH 2) are the active components of the differential amplifiers. R306 and R362 are for calibration of the maximum sensitivity of the VOLTS/CM switches. R305 and R361 are directly connected to the VOLTS/CM VARIABLE knobs on the panel.

From this stage, the output is fed to the common output amplifier through the diode gate circuit.

CH 1 INV switch: The function of S302 is to invert the polarity of the signal received from the preceding stage.

CH 2 ONLY: A 2-stage trigger amplifier which amplifies the trigger signal to an appropriate level for triggering with its Q316, Q317 and W318 is incorporated in CH 2.

Switching circuit: The switching circuit consists of two diode gate circuits, blocking oscillator, and multivibrator. For operation with CH 1 alone, the blocking oscillator (Q311) and multivibrator (Q312 and Q313) are idle but Q312 conducts, the voltage is supplied to the emitters of Q301 and Q302, and CH 1 is in the operating status. Regarding CH 2, on the other hand, Q313 is cut off, no voltage is supplied to the emitters of Q314 and Q315 and, therefore, CH 2 is idle.

Output amplifier: This DC amplifier amplifies the signal received from the emitter follower of the input amplifier (Q305 and Q306) of the preceding stage into a level sufficient to drive the electron beam of the CRT. The signals applied to Q307 and Q308 drive the emitters of base-grounded transistors Q319 and Q320, respectively.

The NORM trigger signal is supplied from the emitter follower (Q306) and applied to the time axis through

Q309. The function of the capacitor connected between emitters of Q307 and Q308 are for high frequency compensation of this stage.

## 5.2 HORIZONTAL CIRCUIT

**Trigger amplifier:** The circuit of Q401 and Q402 is incorporated with S402 so that a negative-going output is provided for either positive-going or negative-going trigger signal. When the Schumitt circuit (Q403 and Q404) of the next stage is in the AUTO mode, these bias voltages are fixed and the output is fed to the next stage in capacitor coupling. When the Schumitt circuit is in the TRIGGER mode, the operating point of Q403 is varied with R425 through Q402.

**Schumitt trigger circuit:** The Schumitt trigger circuit (Q403 and Q404) maintains the trigger signal at a constant amplitude. Thus, a trigger signal of a constant amplitude irrespective of the input is applied to the sweep generator of the next stage.

**Sweep generator:** The Schumitt circuit of Q501 and Q502 operates as a mono-stable multivibrator. The blanking signal is picked off from the collector circuit of Q502, is amplified by Q503, and is applied to the CRT. The sweep generator starts operating when a negative input signal is applied, and Q504 starts miller run up operation. The output is provided by the emitter follower (Q508). A part of this output is fed back to Q501 of the initial stage (in order to hold its operation for an appropriate period) through the hold-off circuit consisting of Q507, CR505, QCR501, and R504. R501, R502, R503, and QCR502 make up a STABILITY circuit for fine adjustment of the bias current of Q501.

Horizontal  
amplifier:

This amplifier amplifies the sweep signal (received from the sweep generator) into a sufficient level to drive the horizontal deflection plates of the CRT. The sweep signal is applied to Q707 through the emitter follower Q704) and drives the emitter of Q706 which is base-grounded. Q706 provides a sufficiently large voltage to drive the horizontal deflection plates. R714 is for horizontal positioning control which varies the operating point of Q705. C707 connected between emitters of Q707 and Q708 is for high range compensation. R728 is for sensitivity control of this stage. R734 is for sensitivity calibration of the 5 X MAG circuit.

### 5.3 SENSITIVITY CALIBRATOR

The auto-run multivibrator consisting of Q801 and Q802 generates a positive-going square wave of approximately 1000 Hz. The collector output of Q802 is applied to Q803 of the next stage. Q803 and CR801 operate as a limiter, and three voltages are supplied through its voltage-dividing resistor circuit.

### 5.4 HIGH VOLTAGE RECTIFIER CIRCUIT

The acceleration voltage for the CRT is obtained through 6-times voltage multiplication rectification of the power transformer output of approximately 250 V AC. Q901 and Q902 make up a control circuit for the 6-times voltage multiplication rectifier circuit in order to maintain constant the acceleration voltage against variation of line voltage or load.

### 5.5 CRT CIRCUIT

The unblanking signal cuts off the CRT beam from the end of the sweep operation of the time axis until the start of the next sweep operation.

The beam is cut off by applying the blanking signal from Q503 of the sweep generator to the control grid of the CRT through R514, R926, R927, R928, and C918. Q903 operates as a constant current transistor and has a function to prevent waveform degradation by integrating the blanking signal by feeding it through R514, R926, and R927. The chopped blanking signal is applied from the blocking oscillator to the CRT cathode through emitter follower Q310.

## 5.6 POWER SUPPLY

The power supply provides three regulated voltages of +15 V, +50 V and -50 V, and a non-regulated voltage of +200 V. The regulated power supply circuits employ a series control system and are constructed fully in solid-state.

## 6. CALIBRATION

### 6.1 REMOVING THE HOUSING

The oscilloscope is required to be calibrated when it has become to cause measurement errors due to aging of its components after the oscillograph has been used for a long period of time. Controls required for calibration are located on the internal chassis which can be pull out of the housing after removing two screws at the rear and one screw at the bottom of the housing.

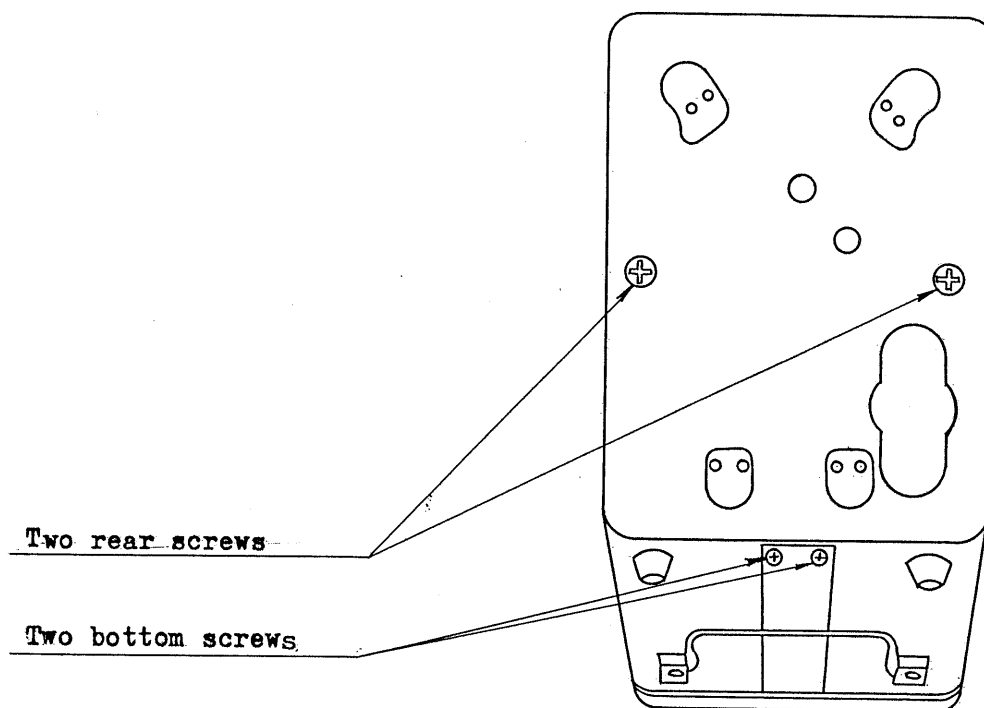

Fig. 6-1

**CAUTION:** TO PREVENT ELECTRIC SHOCK HAZARDS, BE SURE THAT THE POWER SWITCH IS TURNED OFF AND THE POWER CORD IS DISCONNECTED FROM THE AC LINE OUTLET BEFORE REMOVING THE CHASSIS FROM THE HOUSING.



## 6.2 ADJUSTMENTS

### DC GAL Adjustment:

- (1) Set the MODE switch in the CH 1 position and the AC-DC-GND switch in the GND position.
- (2) Move the trace to the scale center by turning the vertical POSITION control of CH 1.
- (3) Turn the VARIABLE knob of VOLTS/CM switch for trial. If the trace moves vertically as a result, turn the DC BAL control so that the trace remains stationary. As the DC BAL control is turned, the trace moves vertically. Move the trace to the center position with the vertical POSITION knob each time the DC BAL control is turned.

The adjusting procedure for the CH 2 is the same with the above.

### STABILITY Adjustment:

- (1) Apply to the vertical input terminal of CH 1 a sine wave signal of 10 kHz ~ 50 kHz.
- (2) Adjust the displayed waveform to a vertical amplitude of 1 cm with the VOLTS/CM switch and to one cycle or two with the TIME/CM switch.
- (3) Set the TRIGGERING LEVEL switch in the AUTO position, the SOURCE switch in the NORM position, and the SLOPE switch in the "+" position.
- (4) The sweep operation stops when the STABILITY control (semi-fixed resistor R502) is turned counterclockwise. Set it in a position immediately before stopping of sweep. (The control is located on the front panel.)

- (5) Turning alternately the TIME/CM switch and VARIABLE knob, check that triggering is stably made at any range.
- (6) Vary the measured signal for a range of 20 Hz ~ 7 MHz, and check that triggering is successfully made within this range. If triggering is unstable, re-adjust the STABILITY control.

ASTIG Adjustment:

The ASTIG control (semi-fixed resistor) is mounted on a printed board at the rear of the oscilloscope.

- (1) Display a sine wave for a full scale of the CRT.
- (2) Adjust the ASTIG control, in conjunction with the FOCUS control, so that the sharpness (focussing) of the trace is made uniform.

6.3 VOLTAGE SENSITIVITY OF VERTICAL AXIS

- (1) Set the VOLTS/CM switch in the 0.01 position.
- (2) Set the VARIABLE knob in the CAL'D position.
- (3) Apply to the input terminal a square wave of 0.04 Vp-p.
- (4) Adjust R306 (for CH 1) and R362 (for CH 2) so that the vertical amplitude of the displayed waveform is made 4 cm.

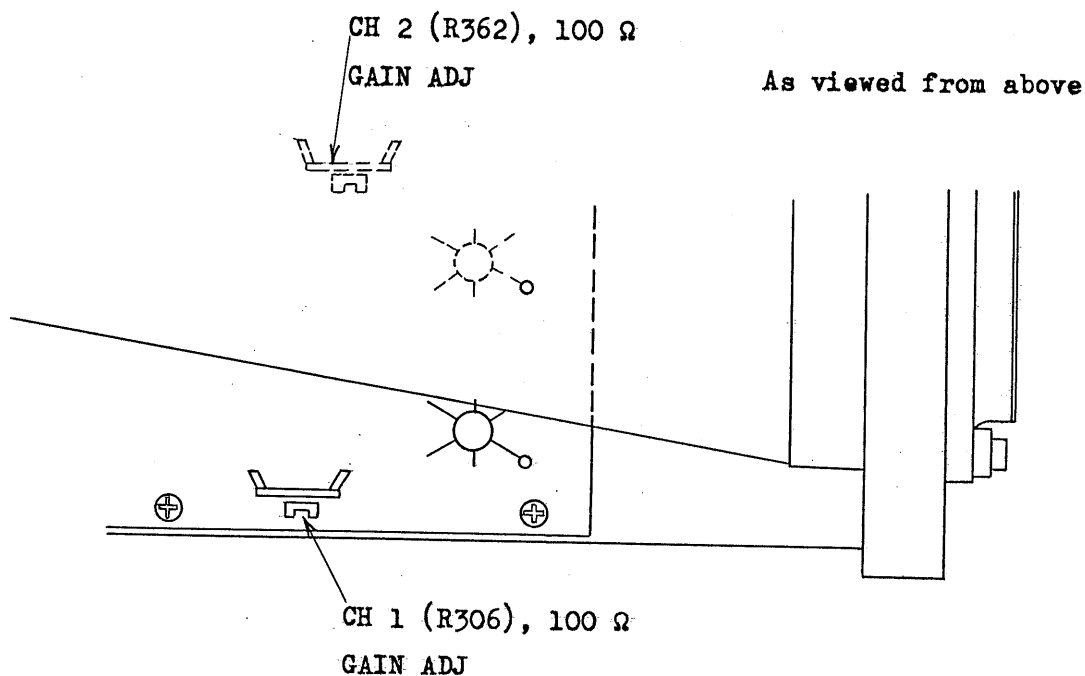

Fig. 6-2

#### 6.4 CALIBRATION OF VOLTS/CM

Input capacitance and frequency characteristics should be adjusted for the VOLTS/CM of the VOLTS/CM switch.

##### Input Capacitance

- (1) Connect to the vertical input terminal a capacitance meter which can measure capacitances at approximately 38 pF.
- (2) Set the VOLTS/CM switch in the 0.01 position.
- (3) Adjust the input capacitance to 38 pF with C201 (for CH 1) and C205 (for CH 2).
- (4) Set the VOLTS/CM switch in the 0.02 position
- (5) Adjust the input capacitance to 38 pF with C104.

| VOLTS/CM | Trimmer capacitor        | Adjusted value |
|----------|--------------------------|----------------|
| 0.01     | C201 (CH 1), C205 (CH 2) | 38 pF          |
| 0.02     | C104                     | 38 pF          |
| 0.05     | C108                     | 38 pF          |
| 0.1      | C113                     | 38 pF          |
| 1        | C117                     | 38 pF          |
| 10       | C121                     | 38 pF          |

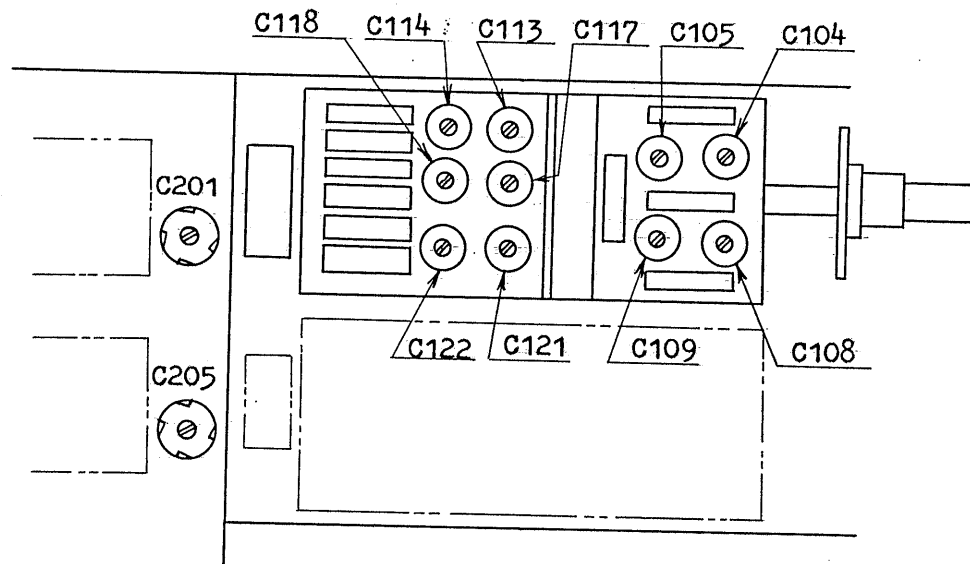

Fig. 6-3

The trimmer capacitors are located in the identical positions for both CH 1 and CH 2, but on different printed boards.

Frequency Characteristics (Compensator):

- (1) Apply to the vertical input terminal of the oscilloscope the output of a pulse generator which provides a quality waveform signal of repetition frequency of 1 kHz covering voltages of 0.04 ~ 80 Vp-p.
- (2) Set the VOLTS/CM switch in the 0.02 position.
- (3) Adjust the waveform as shown in Fig. 6-4 by adjusting capacitors C105 ~ C122 as tabulated below.

| VOLTS/CM | Trimmer capacitor |
|----------|-------------------|
| 0.02     | C105              |
| 0.05     | C109              |
| 0.1      | C114              |
| 1        | C118              |
| 10       | C122              |

The trimmer capacitors are located in the identical positions for both CH 1 and CH 2, but on different printed boards.

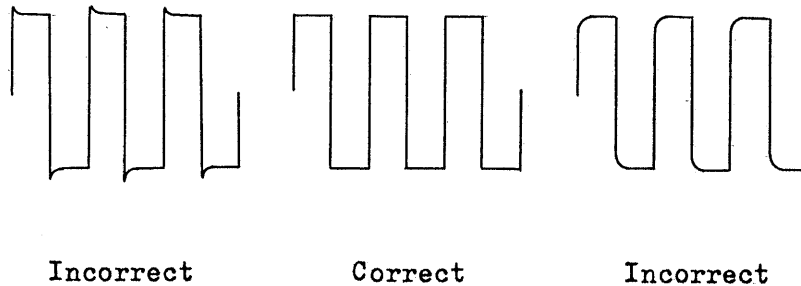

Fig. 6-4

- (4) When the above adjustment is made, the input capacity varies slightly. Re-adjust the input capacity.

#### 6.5 ADJUSTMENT OF CALIBRATION VOLTAGE--(CALIB Vp-p)

The voltage sensitivity must have been calibrated for all ranges of the VOLTS/CM switch.

- (1) Set the VOLTS/CM switch of CH 1 in the 1 V position.
- (2) Set the VARIABLE knob in the CAL'D position.
- (3) Apply the 5 Vp-p CALIB output to the input terminal of CH 1.
- (4) So adjust R809 that the vertical amplitude of the displayed waveform is made 5 cm.

#### 6.6 ADJUSTMENT OF SWEEP TIME

- (1) Apply the time marker generator output to the vertical input terminal.
- (2) Set the TIME/CM switch in the 1 mS position and the VARIABLE knob in the CAL'D position.
- (3) Set the time marker generator output at 1 mS.
- (4) Align the marker signal with the graticule scale by means of semi-fixed resistor R728.
- (5) Pull out the PULL 5 X MAG knob, and adjust the magnification factor by means of R734.

For the 1 S - 50  $\mu$ S ranges, the adjustment is complete by the above procedure. For the 20  $\mu$ S ~ 1  $\mu$ S ranges, use the trimmer capacitors also for aligning the marker with the scale.

| TIME/CM    | Control |  |
|------------|---------|--|
| 1 mS       | R728    |  |
| 10 $\mu$ S | C611    | Adjustment must be made after that for 1 mS range is complete. |
| 1 $\mu$ S  | C615    |  |

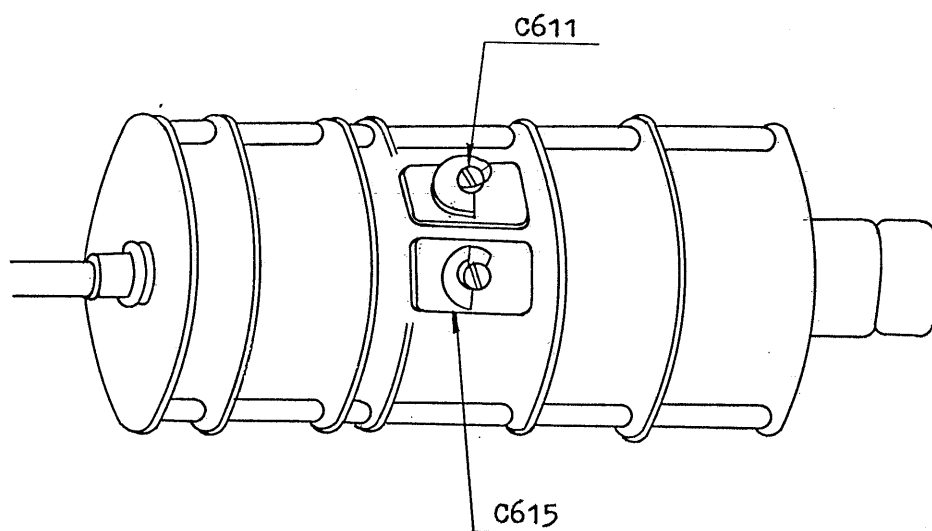

Fig. 6-5

#### 6.7 ADJUSTMENT OF SWEEP AMPLITUDE

The trace amplitude when the PULL 5 X MAG knob is pushed-in is approximately 10.5 cm. This adjustment must be made after the adjustment of the sweep time is complete. This adjustment is primarily for checking and does not require to be precisely made. If the amplitude is less than 10 cm, make adjustment by means of semi-fixed resistor R531.

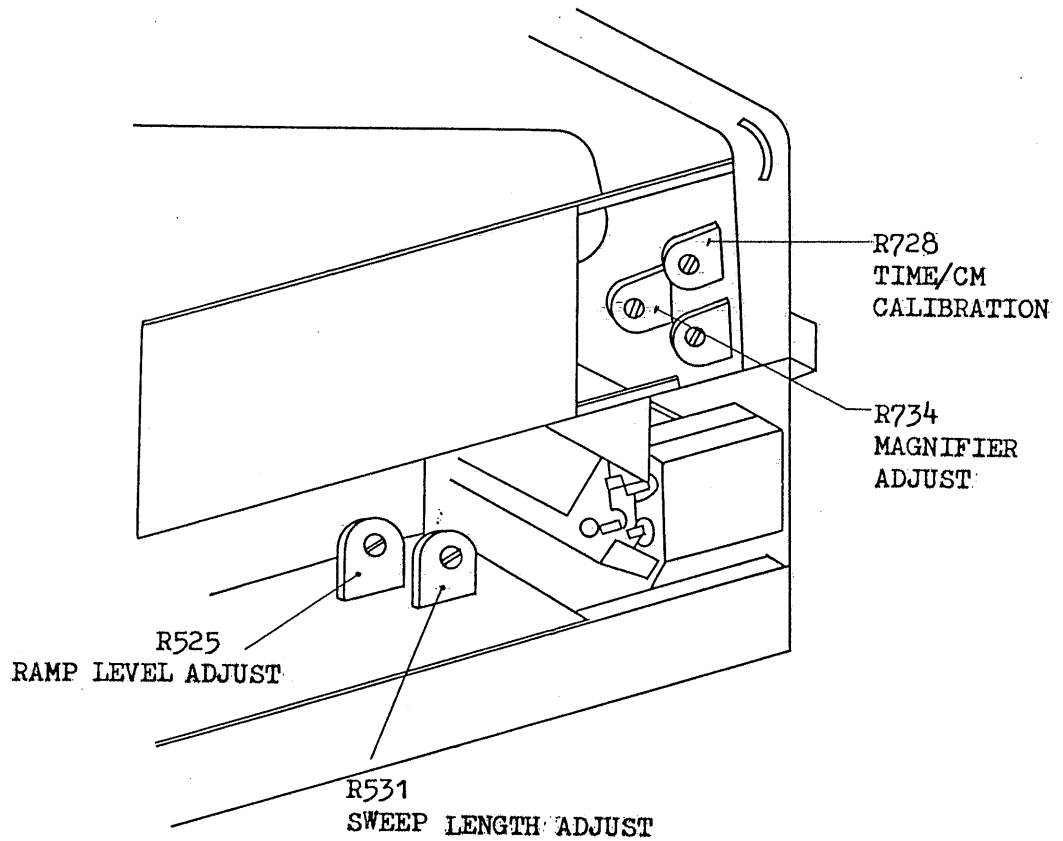

Fig. 6-6

#### 6.8 MAINTENANCE OF PROBE

The accessory probe (low capacitance type) is required to be periodically adjusted because its characteristics are disturbed when an unreasonably large mechanical shocks or high voltages are applied to it. The probe houses voltage-dividing precision resistors and a trimmer capacitor for high frequency range compensation. The optimum adjusted position of the trimmer capacitor can be disturbed when unreasonably large mechanical shocks are applied to the probe and, therefore, the trimmer capacitor is required to be adjusted.



## 6.9 ADJUSTMENT OF TRIMMER CAPACITOR

- (1) Connect the probe to the vertical amplifier.
- (2) Apply to the probe tip a square wave signal of approximately 1000 Hz.
- (3) Make the displayed signal the correct waveform by turning the trimmer capacitor in the compensator box of the box with a screwdriver.

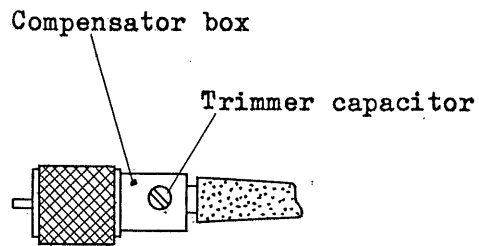

Incorrect waveform

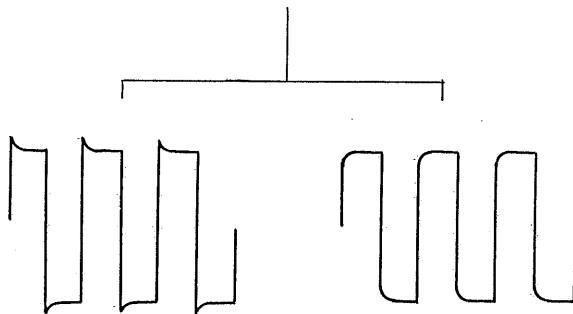

Correct waveform

